

# GARMIN®

## Fishfinder 120

### Installation Instructions

Please read through these instructions thoroughly before attempting installation. Make sure you completely understand these instructions before you begin. When in doubt, seek professional assistance. Be sure the wiring harness reaches the unit and transducer location before beginning installation. The Garmin Fishfinder 120 hardware allows for installation on either the transom or trolling motor. Please check the packing list below. If you are missing any items, please contact your Garmin dealer.

#### Packing List:

- |   |                            |
|---|----------------------------|
| A - Fishfinder 120 Sonar Unit (1)       | J - 5 x 30 mm Screws (2)   |
| B - Swivel Mount Bracket (1)            | K - 10-32 Lock Nut (1)     |
| C - Swivel Base (1)                     | L - 4 x 12 mm Screws (4)   |
| D - Mounting Knobs- Short (1), Long (1) | M - 10-32 x 1.75 Screw (1) |
| E - Mounting Knob Spacer (1)            | N - 1/4" Cable Clamps (2)  |
| F - Transducer With Power Cable (1)     | O - Plastic Spacer (1)     |
| G - Transducer Mount (1)                | P - 1/4" Rubber Washer (1) |
| H - Trolling Motor Mount Gasket (1)     | Q - Cable Tie, 5.6" (4)    |
| I - 5 mm Flat Washers (2)               | R - Cable Tie, 20" (1)     |
|   | S - Snap-Ring (1)          |

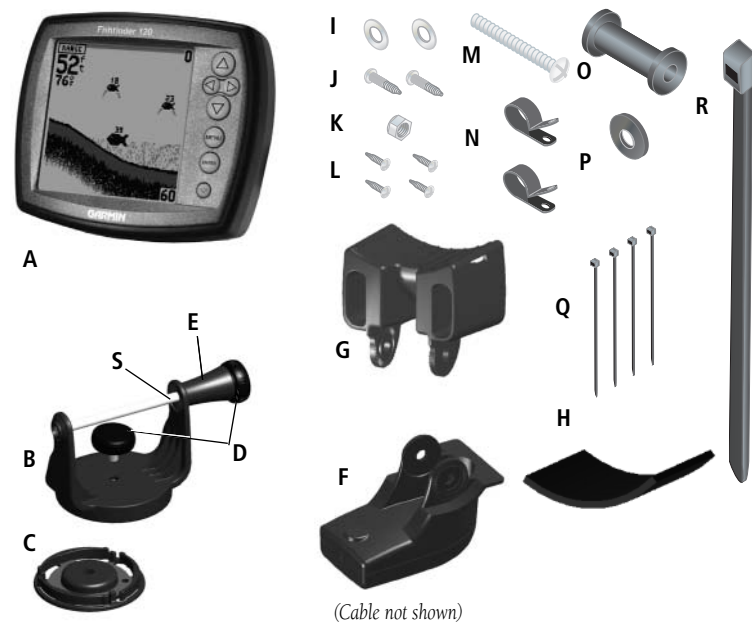

#### Assembling the Transducer

1. Insert the Rubber Washer and Plastic Spacer in the transducer at the same time. DO NOT lubricate the Rubber Washer.
2. Route the cable towards the back and slide the transducer into the mounting bracket.
3. Place a 5 mm Flat Washer on the 10-32 x 1.75" screw and insert the screw through the Mounting Bracket, Spacer, and Rubber Washer.
4. Place the remaining 5 mm Flat Washer on the exposed end and install the 10-32 Lock Nut finger tight. The transducer is tightened further after installation on boat.

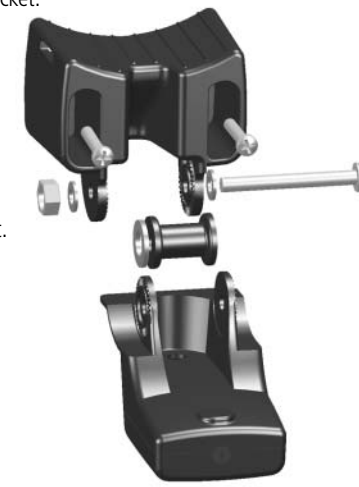

#### Mounting the Transducer On a Trolling Motor

1. Slide the large Cable Tie through slot on the Transducer Mount with the ridges of the band facing up until equal lengths extend on both sides of the mount. (For cold water or heavy timber/debris areas, a metal 4-5" worm gear clamp is recommended.)
2. Position the Mount Gasket on the curved top of the Mount.
3. Place the transducer assembly against the motor body of the trolling motor with the front of the transducer pointed away from the trolling motor propeller.
4. Place the pointed end of Cable Tie through the fastener hole on the opposite end and pull through (you will hear clicks) until snug.
5. Position the transducer so that it is parallel with the bottom when in use. Make sure the Gasket is aligned properly. Pull the Cable Tie end until tight. Excess may be trimmed off if needed. Tighten the 10-32 locking nut until it touches the mounting bracket and then tighten 1/4 turn more (do not overtighten).
6. Route the 20' (6.1 m) transducer cable using the supplied cable ties to secure the cable to the motor shaft. If desired, the forward-facing portion (except the Cable Tie pocket) of the Transducer Mount may be filled with sealant to avoid debris accumulation.

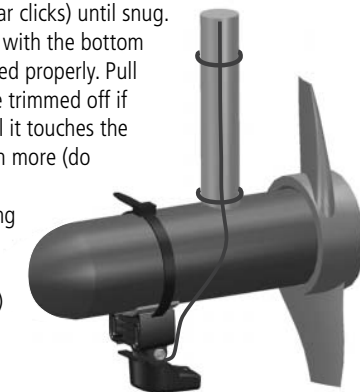

#### Selecting a Transom Mount Location

For your sonar to operate properly, the transducer has to be located in clean (non-turbulent) water. The transducer should be mounted as near the center of the boat as possible.

**DO NOT** cut the transducer lead, this will void your warranty and may cause the unit to not operate at optimal levels.

**DO NOT** mount the transducer behind strakes, rivet lines, struts, fittings, water intake, discharge ports, eroding paint, or anything that creates air bubbles or causes the water to become turbulent. It is important that the transducer be as close to the center line as possible in calm, non-turbulent water for optimal performance. Avoid mounting the transducer in locations where the boat may be supported during launching, hauling, trailering, or storage.

Mount the transducer away from the path of the prop on single drive boats. On twin drive boats, mount the transducer between the drives if possible. Do not mount the transducer directly in the path of the prop. The transducer can cause cavitation that may degrade the boat's performance and damage the prop.

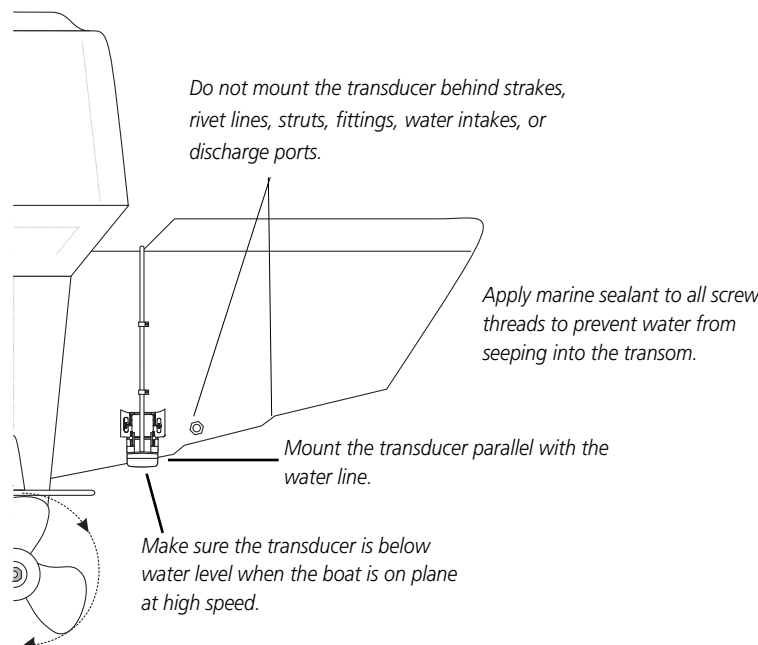

#### Mounting the Transducer On a Transom

**Tool List (not included)** - Drill, 3/8" Wrench or Socket, 5/32" and 1/8" Drill Bits, Masking Tape, #2 Phillips Screw Driver, Marine Sealant

1. Position the transom mount at the selected location, making sure the transducer is parallel with the water line. Mark the center locations of each hole on the transom mount. (See figures to the right.)
2. Using the 5/32" bit, drill the pilot holes approximately 1" (25 mm) deep at the marked locations. To avoid drilling the holes too deep, wrap a piece of tape around the bit 1" from the point of the bit.
3. Apply Marine Sealant to the 5 x 30 mm screws. Attach the transducer to the transom using the 5 x 30 mm screws. Adjust the transducer to extend beyond the bottom of the transom approximately 1/8" (3 mm) on fiberglass hulls or 3/8" (10 mm) on aluminum hulls. Adjust the transducer to be aligned parallel with the water.
5. Tighten the 10-32 locking nut until it touches the mounting bracket and then tighten 1/4 turn more (do not overtighten).
6. Place the first cable clamp on the transducer cable approximately one third of the distance between the transducer and the top of the transom. Mark the location. Using a 1/8" bit, drill a pilot hole approximately 3/8" (10 mm) deep.
7. Attach the cable clamp using a 4 x 12 mm screw. Coat the screw with marine sealant before installation. Repeat steps 6 and 7 using the other cable clamp.
8. Route the transducer cable as needed to the sonar unit. DO NOT CUT THE CABLE. Try to avoid routing the cable with electrical wires or other sources of electrical interference.

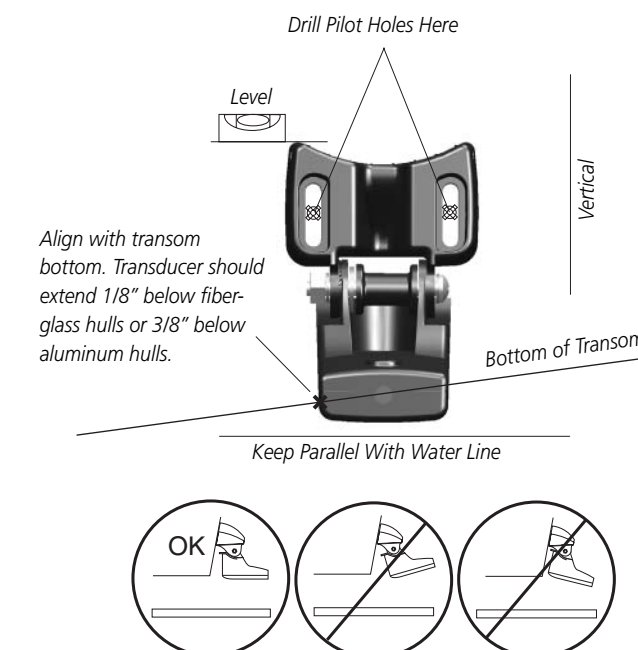

#### Unit Installation — Selecting a Proper Location

Choose a location that provides optimal viewing while operating the vessel and allows easy access to the unit's keypad. Select a mounting surface strong enough to support the weight of the unit and protect it from excessive vibration or shock. DO NOT mount the bracket in a location where the unit is exposed to extreme temperature conditions. When installing the mounting bracket, be sure to allow room for the connection/routing of the power cable.

#### Mounting the Bracket Assembly

**Tool List (not included)** - Drill, Screwdriver (Phillips or Standard), three #8 pan head machine bolts with matching nuts and washers and a 5/32" drill bit, OR three #8 pan head self-tapping screws and a 1/16" drill bit

1. Using the swivel base as a template, mark the location of the three holes which are used to secure the bracket to the mounting surface.
2. If securing the base with machine bolts, drill three 5/32" holes at the locations you marked. OR, If securing the base using self-tapping screws, drill 1/16" starter holes at the locations you marked. Starter holes should generally be no deeper than half the screw length.
3. Secure the swivel base with three bolts or screws. DO NOT OVERTIGHTEN.
4. Place the rest of the mount over the swivel base and secure with the short knob.

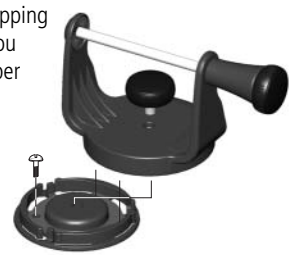

#### Installing the Unit On the Mounting Bracket

1. Align the slot on the back of the unit with the long mounting knob and slide in place. It may be necessary to adjust the long knob to spread the bracket arms apart. (Turn counter-clockwise to widen the bracket arms, clockwise to tighten.)
2. Adjust the unit angle and tighten the long mounting knob until snug.
3. Tilt the unit by loosening the long knob on the right side of the bracket assembly.
4. Rotate the entire bracket by twisting it left or right. (You will hear clicks as you turn the bracket.)
5. Tighten all knobs once the desired viewing angle is obtained.



#### Wiring Harness Installation

The Fishfinder 120 comes with a wiring harness that connects the unit to power and the transducer with one easy-to-remove connection. If it is necessary to extend the power wires, use 22 AWG wire. DO NOT cut the transducer cable. This will void your warranty. If your boat has an electrical system, it may be possible to wire the unit directly to an unused holder on your current fuse block. If you are using the boat's fuse block, remove the in-line fuse holder supplied with the unit. You may also wire the unit direct to the battery. **CAUTION: The Fishfinder 120 input voltage is 10-18 volts DC.** DO NOT exceed this voltage as this may damage the unit and void the warranty.

#### Installing the Wiring Harness:

1. Determine the polarity of the power source using a Test Light or Volt Meter.
2. Install the Red (+) wire on the Positive fuse holder or battery terminal.
3. Install the Black (-) wire on the Negative fuse holder or battery terminal.
4. Install a 2 amp fuse in the fuse holder (fuse block only).
5. Align the notches on the cable plug and back of the unit. Insert the cable into the connector and turn the lock ring counter-clockwise until it stops.

#### Unit Care

**Cleaning** - Clean the unit housing using a cloth lightly dampened with a mild detergent solution and then wipe dry. Avoid chemical cleaners and solvents that may damage plastic components. Do not apply cleaner to electrical contacts on the back of the unit.

**Storage** - Do not store the unit where exposure to temperature extremes may occur, as permanent damage may result.

#### Testing the Transom Mount Installation

This test is to be performed after the unit installation. See unit operating instructions for additional use information. Since water is necessary to carry the sonar signal, the Fishfinder 120 does not function properly with the transducer out of the water. When you place your boat in the water CHECK FOR LEAKS around the screw holes that are below the water line. DO NOT leave your boat in the water for an extended period of time without checking for leaks.

1. Begin testing the installation at a slow speed. If the sonar appears to be working properly gradually increase the boat's speed observing the sonar's operation. If the sonar signal suddenly is lost or the bottom return is severely degraded, note the speed at which this occurs.
2. Return the boat to the speed the signal was lost. Make moderate turns in both directions and see if the signal improves.
3. If the signal strength improves while turning, adjust the transducer so that it extends another 1/8" below the transom of the boat. It may take several adjustments to eliminate the degradation.
4. If the signal does not improve it may be necessary to move the transducer to a different location.



# GARMIN® Fishfinder 120

## Operational Instructions

Thank you for choosing the Garmin Fishfinder 120. This product is designed for easy operation and to provide years of reliable service. Please read through these instructions to get the most out of your new unit. If you encounter a problem please contact our Product Support Department at 913-397-8200, Monday - Friday 8:00 a.m. to 5:00 p.m. CST or on the internet at [www.garmin.com/support](http://www.garmin.com/support).

### Specifications

Case: Fully Gasketed, high-impact plastic alloy  
 Display: 3.1"H x 3.2"W (7.9 x 8.1 cm), 240 x 128 pixels  
 Size: 6.1" W x 4.9" H x 2.6 D (15.5 x 12.5 x 6.6 cm); Weight: 18.7 oz.  
 Temperature Range: +5° to 158°F (-15C to 70C)  
 Waterproof: IEC 529, level IPX-7 (submerged to 1 meter for 30 minutes)  
 Internal memory backup to retain user settings  
 Input: 10 to 18 Vdc w/ high voltage protection  
 Usage: 8 watts maximum, Nominal: 12 Vdc @ 0.5 amps  
 Sonar Power Output: 100 watts (RMS), 800 watts (peak to peak)  
 Frequency: 200kHz  
 Depth: 600 foot max depth (Depth capacity is dependent on water salinity, bottom type and other water conditions.)  
 Specifications subject to change without notice.



### ARROW KEYS

The **UP** and **DOWN ARROW** keys are used to select items on the Adjustment Menu and Setup menu. The **LEFT** and **RIGHT ARROW** keys are used to quickly cycle through Adjustment Menu settings.

### ENTER Key

The **ENTER** key is used to activate/deactivate the Adjustment Menu and Setup Menu data fields for review or changes.

### MENU Key

The **MENU** key is used to activate/deactivate Adjustment and Setup Menus.

### POWER Key

The **POWER** Key is used to turn the unit on/off and to activate the display backlight. Press and hold to turn the unit on/off. Press briefly and release to activate the backlight. To change the backlight level, press the **POWER** key repeatedly to cycle between Off, Low and High.

The Fishfinder 120 is able to display a variety of useful information about the underwater environment. Below are a few things the unit helps you see.

### Water Depth

The unit displays water depth and can provide a warning when a specific depth is encountered. The Depth Scale is displayed from top to bottom along the right side of the display. Messages and Alarm Icons are displayed along the bottom.

### Water Temperature

The unit displays the water temperature at the transducer.

### Fish

The unit displays fish as arches or fish symbols in 3 sizes and can alert you when a fish is detected.

### Thermocline and Structure

GARMIN's See-Thru® technology can display more than just the thermocline and structure, the unit displays fish in and below the thermocline, trees, brush, and deadfall.

### Bottom Shape and Type

Garmin's unique DCG® (Depth Control Gain) system provides a clear graphic representation of the bottom type and its shape.

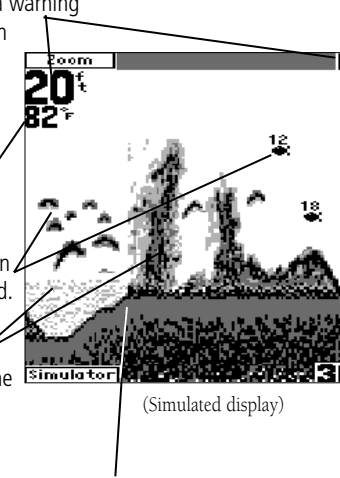

(Simulated display)

### Using the Adjustment Menu

The Adjustment Menu allows direct access to the settings most commonly changed while using the unit. These include the depth Range, Gain, Zoom, and the View settings. Current Adjustment Menu settings may be viewed by pressing the **MENU** key. Press **MENU** again to hide the window or to exit any window. The current adjustment option always displays in the upper left of the display. Press **LEFT** or **RIGHT** on the **ARROW** keys to scroll through the available options.

To immediately change the current adjustment option, press the **UP** or **DOWN ARROW** key. If you wish to review the available settings before making a change, press the **ENTER** key to activate the adjustment window.

### To change a setting on the unit:

1. Press **MENU**, then using the **UP** or **DOWN ARROW** key, move the selection arrow to the desired option and press **ENTER**. Choose 'Setup' for the main Setup Menu.
2. Using the **UP** or **DOWN ARROW** key move the selection arrow to the desired setting and press **ENTER**. (The selection arrow wraps when you reach the end of a menu and adjustment window. If holding the **ARROW** key down, release then press.) Holding down on an **ARROW** key rapidly advances the selection speed.
3. To close a setting or menu window, press **MENU**.



### Adjustment Menu — Range

Sets the display depth range. The unit can be set to automatically track the bottom or set to a user-specified range. Available settings are: 'Auto' (default) and 15-600 ft.

### Adjustment Menu — Gain

Controls the sensitivity of the unit's sonar receiver. This provides some flexibility in what is seen on the display. To see more detail, increase the receiver sensitivity by selecting a higher gain (+). If there is too much detail or if the screen is cluttered, lowering the sensitivity (-) may increase the clarity of the display. Available settings are: 'Normal' ( default) and +5 to -5.

### Adjustment Menu — Scroll

Adjusts the rate that the graph scrolls from right to left. If you are sitting still or the graph is moving too fast, slowing or pausing the graph can be beneficial.

### Adjustment Menu — Zoom

Selects a display zoom scale. Available settings are: 'OFF' (default), '2X' and '4X' zoom.

### Adjustment Menu — View

'View' is available only when a Zoom scale other than 'OFF' is selected. This setting allows you to select a specific zoom area to view on the display or allow the unit to automatically select a zoomed viewing area based on the bottom. When adjusting this setting, the top and bottom numbers reflect the zoomed view depth range.

### Setup Menu — Alarms: Battery

Sounds an alarm when the battery is reaching a critical state of discharge.

### Setup Menu — Alarms: Shallow/Deep Water Alarm

'Shallow' and 'Deep' can be set to sound a shallow/deep water warning at a depth determined by you. (If the either alarm is set and 'Depth' units are changed, both alarms default to 'Off'.) These alarms may be set to 'Off' (default) or from 1-600 ft.

### Setup Menu — Alarms: Fish Alarm

Sounds an alarm when the unit detects what it determines to be a fish. The alarm selections are: 'Off' (default) or 'On'.

### Setup Menu — Graph: Fish ID

Determines how the graph displays underwater targets and background information. If 'Fish ID' is set to 'Off', the unit displays all of the available information about the underwater environment. If a fish symbol is selected, the graph displays only the information related to that symbol (large, medium and small sizes).

**fff** — All available information is displayed. (default)

**ff** — Suspended targets displayed as symbols. No background information is displayed in this mode.

**f** — Same as above with target depth displayed.

**ff** — Suspended targets display as symbols. In this mode background information is still displayed making fish identification easier.

**ff** — Same as above with target depth displayed.

Zone is not detected by the sonar. The fish is never detected since the bottom level is never set below the fish. The fish on the right side of the display (shown in light grey) is detected and displayed when the transducer cone passes over the fish.

It is important to understand that the unit does not display a 3-D representation of the underwater environment. The unit can display multiple things (such as a fish and a tree) at the same time but can not determine where the return originated, only when it was received. Remember that the Fishfinder displays a 2-D picture of the underwater environment. A fish and an underwater structure could be located anywhere in the coverage area at that slice of time.

**Warning:** This product, its packaging, and its components contain chemicals known to the State of California to cause cancer, birth defects, or reproductive harm. This Notice is being provided in accordance with California's Proposition 65. If you have any questions or would like additional information, please refer to our web site at [www.garmin.com/prop65](http://www.garmin.com/prop65).

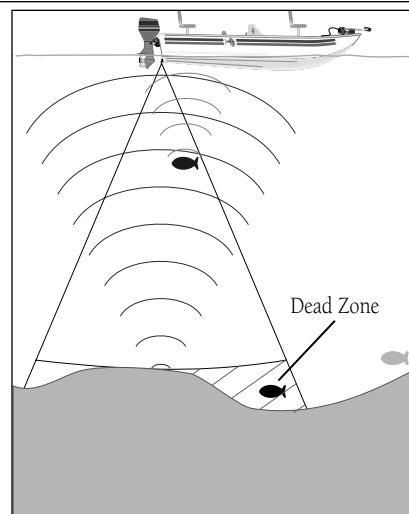

### Setup Menu — Graph: Whiteline

Controls how the unit displays information about the bottom type (hard or soft). With Whiteline 'Off', the bottom return displays as solid black and contains no information on bottom hardness. With Whiteline 'On', the bottom return becomes a grayscale pattern and can be used to determine bottom hardness. A hard bottom returns a stronger signal and displays a thicker bottom layer. A weaker (soft) bottom return displays a thinner bottom layer. The selections are: 'Off' or 'On' (default).

### Setup Menu — Graph: Noise Reject

Filters unwanted noise from the graph (especially when moving at faster speeds) and can be turned 'Off' or set to a fixed value from 1-100%. Remember when setting the 'Noise Reject', the higher the noise rejection setting, the more likely the unit does not show fish or structure. The selections are: 1-100% (default 50%) or 'Off'.

### Setup Menu — Numbers: Size

Displays either 'Normal' (default) or 'Large' depth, temp. and battery numbers.

### Setup Menu — Numbers: Battery

Choose to either 'Hide' (default) or 'Show' the current battery voltage.

### Setup Menu — Numbers: Water Temp.

'Water Temp' automatically displays when set to 'Auto' (default) or you may choose to 'Hide' the temperature numbers. Water temperature will only display if you have a temperature capable transducer.

### Limited Warranty

This Garmin product is warranted to be free from defects in materials or workmanship for one year from the date of purchase. Within this period, Garmin will at its sole option, repair or replace any components that fail in normal use. Such repairs or replacement will be made at no charge to the customer for parts or labor, provided that the customer shall be responsible for any transportation cost. This warranty does not cover failures due to abuse, misuse, accident or unauthorized alteration or repairs.

THE WARRANTIES AND REMEDIES CONTAINED HEREIN ARE EXCLUSIVE AND IN LIEU OF ALL OTHER WARRANTIES EXPRESS OR IMPLIED OR STATUTORY, INCLUDING ANY LIABILITY ARISING UNDER ANY WARRANTY OF MERCHANTABILITY OR FITNESS FOR A PARTICULAR PURPOSE, STATUTORY OR OTHERWISE. THIS WARRANTY GIVES YOU SPECIFIC LEGAL RIGHTS, WHICH MAY VARY FROM STATE TO STATE.

IN NO EVENT SHALL GARMIN BE LIABLE FOR ANY INCIDENTAL, SPECIAL, INDIRECT OR CONSEQUENTIAL DAMAGES, WHETHER RESULTING FROM THE USE, MISUSE, OR INABILITY TO USE THIS PRODUCT OR FROM DEFECTS IN THE PRODUCT. Some states do not allow the exclusion of incidental or consequential damages, so the above limitations may not apply to you.

Garmin retains the exclusive right to repair or replace the unit or software or offer a full refund of the purchase price at its sole discretion. SUCH REMEDY SHALL BE YOUR SOLE AND EXCLUSIVE REMEDY FOR ANY BREACH OF WARRANTY. Products sold through online auctions are not eligible for rebates or other special offers from Garmin. Online auction confirmations are not accepted for warranty verification. To obtain warranty service, an original or copy of the sales receipt from the original retailer is required. Garmin will not replace missing components from any package purchased through an online auction. To obtain warranty service, contact your local Garmin authorized dealer. Or call Garmin Customer Service for shipping instructions and a RMA tracking number. The unit should be securely packed with the tracking number clearly written on the outside of the package. The unit should then be sent, freight charges prepaid, to any Garmin warranty service station. A copy of the original sales receipt is required as the proof of purchase for warranty repairs.

The Fishfinder 120 has no user-serviceable parts and is fastened shut with screws. Any attempt to open the case to change or modify the unit in any way will void your warranty and may result in permanent damage to the equipment.

### Understanding Sonar

To understand what the unit is displaying, it is important to have a general knowledge of how the unit works and how it determines what to display. The unit operates by transmitting sound waves toward the bottom of a lake, stream, or seabed in a cone shaped pattern. The area covered by the transmitted sound waves is determined by the cone angle of the transducer and the water depth. Using Garmin's standard 20° transducer, the coverage is approximately 1/3rd of the water depth. The coverage area at a 30-foot depth is approximately a 10-foot diameter circle.

When a transmitted soundwave strikes an underwater object, sound is reflected back to the transducer. The transducer collects the reflected sound waves and sends the data to the unit to be processed and displayed on the graph. The underwater data is displayed on the graph in the order that it is returned: first returned—first on the graph. Generally speaking, if the only thing between the transducer and the bottom is water, the first strong return comes from the bottom directly below the transducer. The first strong return sets the bottom level. Weaker secondary returns provide the detailed data. A fish may be in the coverage area of the transducer, but remember the first strong return sets the bottom level. Any fish in a Dead

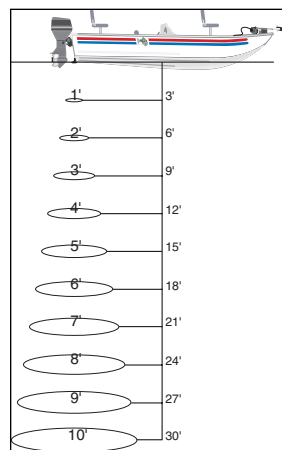

### Software License Agreement

By using the Fishfinder 120, you agree to be bound by the terms and conditions of the following software license agreement. Please read this agreement carefully.

Garmin grants you a limited license to use the software embedded in this device (the "Software") in binary executable form in the normal operation of the product. Title, ownership rights and intellectual property rights in and to the Software remain in Garmin.

You acknowledge that the Software is the property of Garmin and is protected under the United States of America copyright laws and international copyright treaties. You further acknowledge that the structure, organization and code of the Software are valuable trade secrets of Garmin and that the Software in source code form remains a valuable trade secret of Garmin. You agree not to decompile, disassemble, modify, reverse assemble, reverse engineer or reduce to human readable form the Software or any part thereof or create any derivative works based on the Software. You agree not to export or re-export the Software to any country in violation of the export control laws of the United States of America.

© Copyright 2003 Garmin LTD. or its subsidiaries

GARMIN®, DCG® and See-Thru® are registered trademarks of Garmin Ltd. or its subsidiaries and may not be used without the express permission of GARMIN.  
 Garmin International, Inc. 1200 East 151st Street, Olathe, Kansas 66062, U.S.A.  
 Tel.913/397.8200 Fax. 913/397.8282  
 Garmin (Europe) Ltd. Unit 5, The Quadrangle, Abbey Park Industrial Estate, Romsey, SO51 9DL, U.K. Tel. 44/1794.519944 Fax.44/1794.519222  
 Garmin Corporation No. 68, Jangshu 2nd Road, Shijr, Taipei County, Taiwan  
 Tel. 886/2.2642.9199 Fax. 886/2.2642.9099

[www.garmin.com](http://www.garmin.com)

Part Number 190-00306-00 Rev. A